



**MODEL
TBK320**

**MARTELLLO DEMOLITORE
HYDRAULIC BREAKER
HYDRAULIKHAMMER
BRISE-ROCHE
MARTILLO DEMOLEDOR**



OPTIONAL

KIT BATTIPALO
PILE DRIVER KIT
BAUSATZ RAMMGLOCKE
KIT ENFONCE-PIEUX
KIT DE CLAVA POSTES

COMPATIBLE TOOLS

 <p>Telaio per Kit Battipalo Pile Driver Kit Bausatz Rammglocke Kit enfonce-pieux Kit para clava postes</p>	 <p>Utensile taglia legna Wide chisel Holzschneidewerkzeug Outil bucheron Puntero de pala ancha</p>
 <p>Utensile battipalo Post driver Rammglocke Outil cloche Puntero clava postes</p>	 <p>Utensile battipalo a tazza Cup post driver Rammglocke Outil cloche Clava postes a campana</p>

Questi attrezzi vengono personalizzati in base alla geometria del palo da piantare.
These tools are customized according to the size of the post to be pounded.
Diese Werkzeuge werden an die Größe des zu pflanzenden Pfahls angepasst.
Outils cloches personnalisables en fonction du diamètre des pieux à enfoncer.
Estas herramientas se personalizan según la medida del poste a plantar.

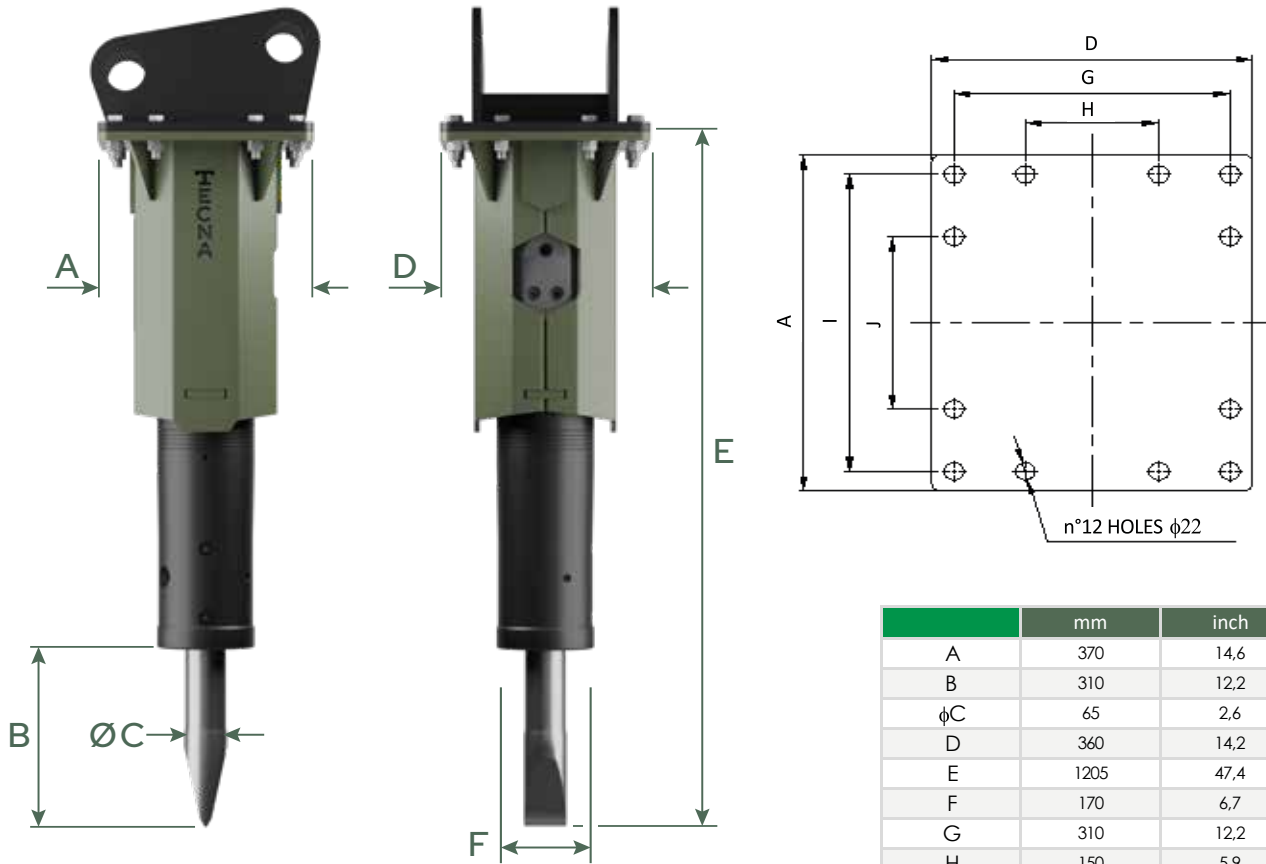

	mm	inch
A	370	14,6
B	310	12,2
φC	65	2,6
D	360	14,2
E	1205	47,4
F	170	6,7
G	310	12,2
H	150	5,9
I	310	12,2
J	170	6,7

La sella non è inclusa nella fornitura.
The top bracket is not included in the supply.
Aufnahme ist nicht im Lieferumfang enthalten.
Platine non comprise.
El cabezal no está incluido en el suministro.

**5,5÷7,0
tons**

PESO ESCAVATORE
SUITABLE EXCAVATOR
GEEIGNET FÜR TRÄGERGERÄT
POIDS PELLE
PESO EXCAVADORA

**75
mm**

DIAMETRO UTENSILE
TOOL DIAMETER
MEISSEL DURCHMESSER
DIAMETRE OUTIL
DIAMETRE PUNTERO

**25
bar**

CONTROPRESSIONE MAX
MAX BACK PRESSURE
MAX STAUDRUCK
CONTRE-PRESSION MAXI
CONTRAPRESION MAX

ITALIANO	ENGLISH	DEUTSCH	FRANÇAIS	ESPAÑOL	METRIC UNIT		IMPERIAL UNIT	
PESO ESCAVATORE	SUITABLE EXCAVATOR	GEWICHTSKLASSE/TRÄGERGERÄT	POIDS PELLE	PESO EXCAVADORA	5,5 ÷ 7	Ton	12125 ÷ 15432	lbs
PESO MEDIO OPERATIVO	OPERATING WEIGHT	EINSATZGEWICHT DES HAMMER	POIDS OPERATIF	PESO MEDIO OPERATIVO	260	kg	573,2	lbs
DIAMETRO UTENSILE	TOOL DIAMETER	MEISSEL-DURCHMESSER	DIAMETRE OUTIL	DIAMETRO PICA	75	mm	2,95	in
PORTATA	OIL SUPPLY	ÖLMENGE MIN/MAX	DEBIT AU BRISE-ROCHE	CAUDAL	55 ÷ 75	l/min	15 ÷ 20	GPM
PRESSIONE DI LAVORO	BREAKER WORKING PRESSURE	BETRIEBSDRUCK DES HAMMERS	PRESSION DE SERVICE	PRESSION EN EL MARTILLO	100 ÷ 150	bar	1450 ÷ 2176	PSI
PRESSIONE REGOLATA ALL'ESCAVATORE	RELIEF PRESSURE SETTING	EINGESTELLTER ARBEITSDRUCK AM BAGGER	PRESSION REGLEE A LA PELLE	PRESSION EN LA EXCAVADORA	180	bar	2611	PSI
CONTROPRESSIONE MAX	MAX BACK PRESSURE	MAX. ZULÄSSIGER RÜCKLAUFSTAUDRUCK	CONTRE-PRESSION MAXI	CONTRAPRESSION MAX	25	bar	363	PSI
POTENZA INGRESSO (MAX)	INPUT POWER (MAX)	MAX. HYDRAULISCHE EINGANGSLEISTUNG	PUISSANCE ENTREE (MAX)	POTENCIA DE ENTRADA (MAX)	19	kW	25,1	HP
CLASSE DI ENERGIA D'URTO	IMPACT ENERGY CLASS	EINZELSCHLAGENERGIE	CLASSE D'ENERGIE D'IMPACT	ENERGIA DE IMPACTO CLASE	990	J	731	ft/lbs
NUMERO DI COLPI AL MINUTO	IMPACT RATE	SCHLAGFREQUENZ PRO MINUTE	FRAPES PAR MINUTE	GOLPES MINUTO	700 ÷ 980	BPM	700 ÷ 980	BPM
TEMPERATURA MAX OLIO IDRAULICO	MAX TEMPERATURE HYDRAULIC OIL	MAX ÖLTEMPERATUR	TEMP. MAX HUILE HYDRAULIQUE	TEMP. MAX DE ACEITE HIDRAULICO	80	°C	176	°F
TUBAZIONE IMPIANTO MANDATA (Ø min.)	RECOMMENDED INLET LINE SIZE (Ø min.)	EINLASSSCHLAUCH (Ø MIN.)	DIAMETRE TUYAU ENTREE. (Ø min)	TUBERIA INSTALACION PRESION (Ø min.)	15	mm	0,59	in
TUBAZIONE IMPIANTO RITORNO (Ø min.)	RECOMMENDED RETURN LINE SIZE (Ø min.)	AUSLASSSCHLAUCH (Ø MIN.)	DIAMETRE TUYAU SORTIE (Ø min.)	TUBERIA INSTALACION RITORNO (Ø min.)	18	mm	0,71	in
LUNGHEZZA CONSIGLIATA TUBI FLESSIBILI	SUGGESTED MIN FLEX HOSES LENGTH	EMPFOHLENE SCHLAUCHLÄNGE	LONGUEUR DES FLEXIBLES	LONGITUD MAXIMA LATIGUILLO	1600	mm	63,0	in
ATTACCO INGRESSO DEMOLITORE	HOSE CONNECTION AT THE BREAKER'S INLET LINE	SCHLAUCHKUPPLUNG - EINLASS	JOINTAGE AU BRISE-ROCHE ENTREE	RACOR RITORNO MARTILLO	3/4" G		3/4" G	
ATTACCO USCITA DEMOLITORE	HOSE CONNECTION AT THE BREAKER'S RETURN LINE	SCHLAUCHKUPPLUNG - AUSLASS	JOINTAGE AU BRISE-ROCHE SORTIE	RACOR PRESSION MARTILLO	3/4" G		3/4" G	